

AM2789 Three Phase Brushless Motor Driver

● Features

- 2.7V to 15V Operating Voltage Range
- 3.5A Maximum Continuous Current
- Wide PWM input operating range to 100KHz
- Low MOSFET ON-resistance: HS + LS = 90mΩ
- Operating ambient junction temperature: -20°C ~85°C
- Built-in precise LDO Regulator 3.3V ±3%
- Turbo current limit function adjusts by external Resistor.
- Over temperature protection
- QFN5 X 5 Package for small PCB layout
- Halogen-Free Green Product & RoHS compliant Package

● Application

- Gimbal
- Robotics
- Consumer products
- Household appliance
- For 1~3 cells Li batteries source application.

● Ordering Information

Part number	Package	Body Size
AM2789	QFN 5X5	5.0mm X 5.0mm

● Description

The AM2789 provides three individual controllable half-bridge drivers. The device is intended to drive a three-phase brushless DC motor, though it can also be used to drive solenoids or other types of load. Each output driver channel consists of P-channel +N-channel power MOSFETs in a half-bridge configuration.

The AM2789 can supply up to 6A peak or 3.5A continuous output current per channel (with proper PCB heat sink at 10V and 25°C) per half-Bridge. There is internal shutdown function for over-temperature protection.

The device provides internal shutdown functions for Short-circuit protection, turbo current limit and over temperature protection.

● **Absolute Maximum Ratings (T_A=25°C)**

Parameter	Symbol	Limits	Unit
Power Supply Voltage	PVCC_X	19	V
Analog Supply Voltage	VCC	19	V
Output Continuous Current	I _{O CONT}	3.5	A
Output Peak Current	I _{O peak}	6	A
Operate Temperature Range	T _{opr}	-20~+85	°C
Storage Temperature Range	T _{stg}	-40~+150	°C

● **ESD Rating**

		Value	Unit
V _(ESD) Electrostatic discharge	Human Body Mode(HBM) ⁽¹⁾	4000	V

(1) The test method refers to JEDEC EIA/JESD22-A114-B.

● **Recommended Operating Conditions (T_A =25°C)**

(Set the power supply voltage taking allowable dissipation into considering)

Parameter	Symbol	Min	Typ	Max	Unit
Power Supply Voltage	PVCC_X	2.7(note)	10	15	V
Analog Supply Voltage	VCC	2.7(note)	10	15	V
PWM_X and STBY_X	V _{PWM_X} / V _{STBY_X}	-0.3	3.3	3.7	V
H-Bridge Output Continuous Current	I _{OUT}			3.5	A
Externally Applied PWM Frequency	F _{PWM}	0.02		100	KHz

Note:

1. The LDO_3.3V operation range should be considered in choosing VCC.
2. The LDO 3.3V operation range should be considered in choosing VCC and LDO voltage drop 0.4V max at I_{LDO}=100mA.

● Electrical Characteristics (Unless otherwise specified, TA = 25°C ,PVCC=VCC=10V)

Parameter	Symbol	Value			Unit	Condition
		MIN	TYP	MAX		
Power Supply						
VCC/PVCC Operating Current 1	I _{CC1}		0.5		mA	PWM_X=STBY_X=L
VCC/PVCC Operating Current 2	I _{CC2}		1		mA	PWM_X=STBY_X=H
LDO						
Output Voltage	V _{LDO}	3.2	3.3	3.4	V	I _{LDO} =100mA, VCC=10V
Dropout Voltage	V _{DO}	—	—	400	mV	I _{LDO} =100mA, V _{LDO} =3.3V
PWM_X/STBY_X Inputs						
Input High Level Logic	V _{PWM_XH} V _{STBY_XH}	2.0		3.5	V	
Input Low Level Logic	V _{PWM_XL} V _{STBY_XL}	0		0.7	V	
Input Frequency	F _{PWM}	0.02		100	kHz	
Input Pull-up Resistance	R _{IPD}		100		KΩ	
Input Pull-down Resistance	R _{IPD}		130		KΩ	
H-Bridge FETs						
R _{ds(on)} HS+LS FET On-resistance	R _{ds(on)}		90		mΩ	I _{Load} = 1A, T _J : 25°C
Current Sense Input						
Current Sense Voltage	V _{CS}	120	150	180	mV	

● Pin configuration QFN 5X5

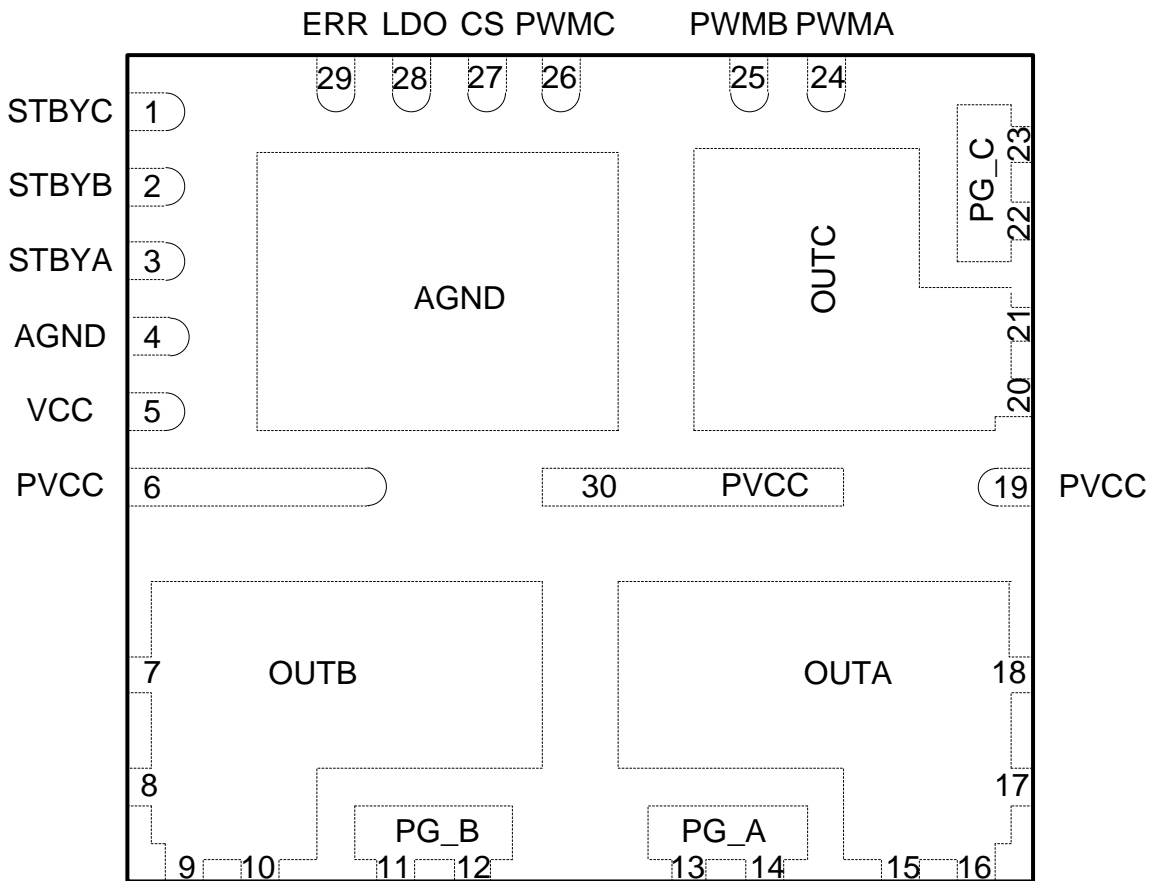

● Pin Descriptions

PIN Number	Pin Name	I/O	Description
1	STBYC	I	Standby Input C
2	STBYB	I	Standby Input B
3	STBYA	I	Standby Input A
4	AGND	-	Analog Ground
5	VCC	-	Analog Power Supply
6, 19, 30	PVCC	-	Power Supply of Half Bridge
7, 8, 9, 10	OUTB	O	Output of Half Bridge B
11, 12	PG_B	-	Power GND of Half Bridge B
13, 14	PG_A	-	Power GND of Half Bridge A
15, 16, 17, 18	OUTA	O	Output of Half Bridge A

20, 21	OUTC	O	Output of Half Bridge C
22, 23	PG_C	-	Power GND of Half Bridge C
24	PWMA	I	Driver Logic Input A
25	PWMB	I	Driver Logic Input B
26	PWMC	I	Driver Logic Input C
27	CS	I	Current Sense
28	LDO	O	Low Dropout Regulator
29	ERR	I	Error Output

● Block Diagram

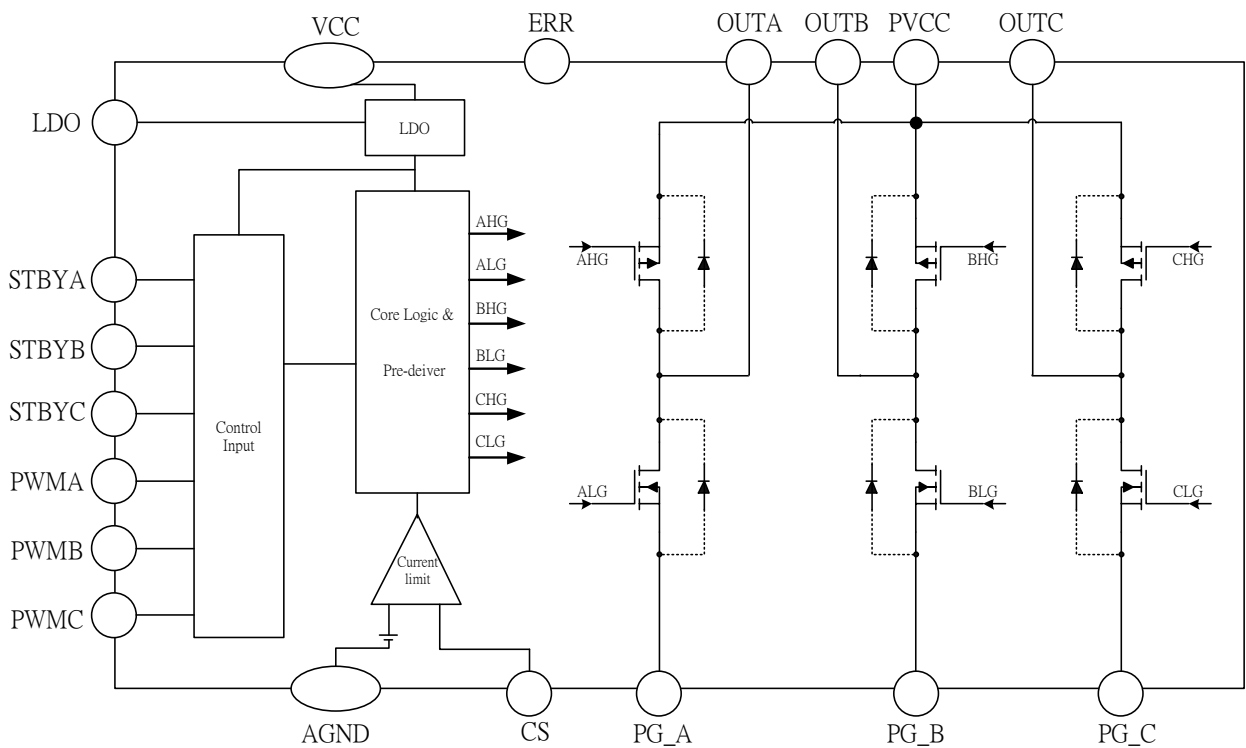

● Application Circuit

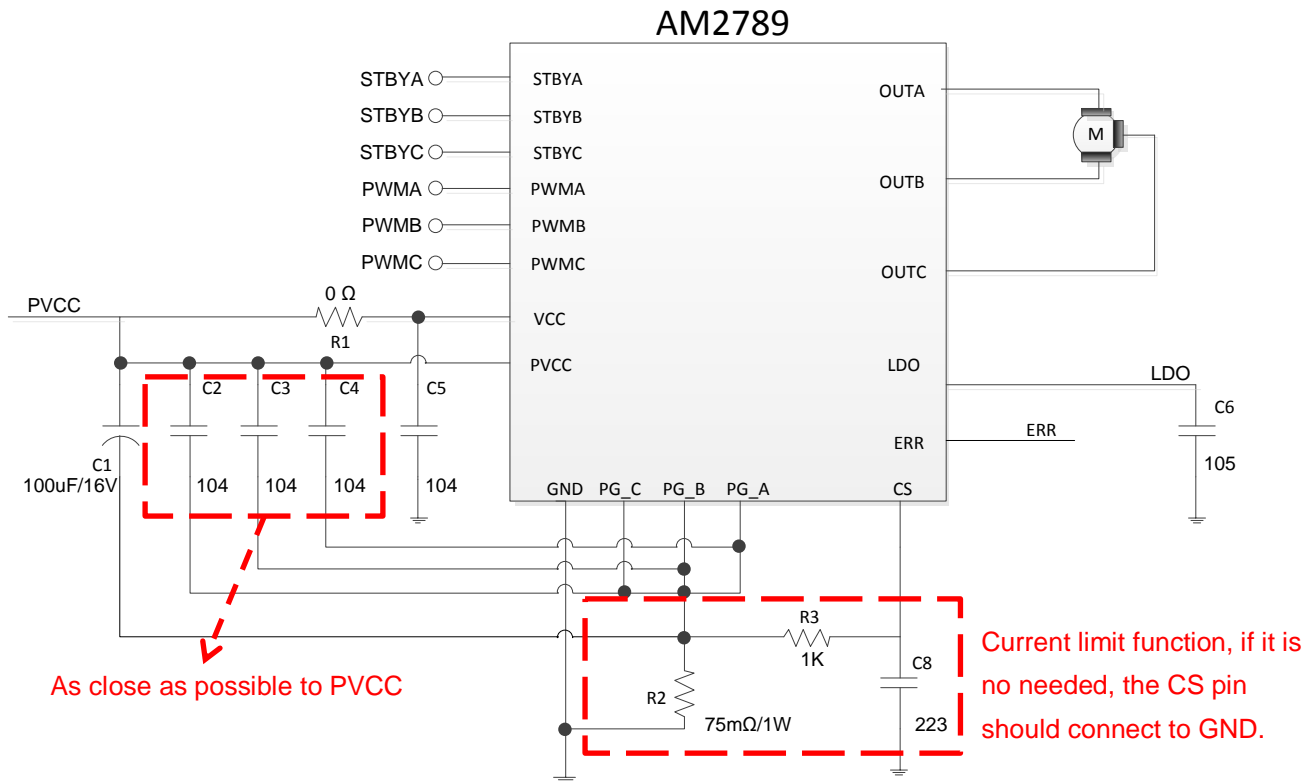

Description:

1. The C1 · C2 · C3 · C4 are power supply stabilization for both PWM driver and kickback absorption. A large capacitor C1 must be used when the coil inductance is large or when coil resistance is low. The pattern connecting to PVCC and GND must be as wide and as short as possible.
2. The C5 is analog power supply stabilization. The pattern connecting to VCC and GND must be as short as possible.
3. AM2789 LDO output are for internal reference voltage using, the Vref and LDO output should be always turn on, C6 capacitor must be connect to GND.
4. R2 is a current sense resistor. R3 and C8 as a low pass filter to catch the voltage of R2 for current sense function. If the current sense function is not needed then short PG_A, PG_B, PG_C, CS PIN to GND
5. ERR PIN can provide an error message to MCU.

● **Application Note**

1) **PVCC Capacitor :**

The PVCC capacitor is power supply stabilization for both PWM driver and kickback absorption. Normally PVCC Capacitor is 47~100uF. The pattern connecting to PVCC and GND must be as wide and as short as possible

2) **VCC Capacitor :**

The VCC capacitor is power supply stabilization. Low pass filter is composed of R and C can be used to suppress PWM driver noise and kickback absorption. Normally R=0ohm, C=0.1uF. The pattern connecting to VCC and GND must be as short as possible.

3) **LDO Capacitor :**

Recommend Capacitor=1μF or more.

4) **CS :**

CS is current limit input pin. There is a reference voltage (150mV_TYP) at input node A of comparator. The input node B of comparator is CS. When input voltage of CS >150mV, that will trigger current limit function to keep output current on setting value.

5) **ERR :**

ERR is an error message output pin. ERR pin can provide an error message to MCU. Error message signal includes TSD function.

When IC is operating normally, ERR keep high level signal, When IC is operating abnormally, ERR pull low level signal which feedback to MCU.

6) **Setting Current limiter design target :**

The current limiter value is calculated in equation

$$I_{LIMITED} = \frac{150mV}{R_{SENSE}}$$

For example:

If design target for current limiter is 3A, the R_{SENSE} value may be calculated as following:

$$R_{SENSE} = \frac{150mV}{I_{LIMITED}} = \frac{150mV}{3A} = 50m\Omega$$

Please follow steps to set up R_{SENSE} value in real application circuit

Step 1. Initial setting R3=1KΩ, then calculate R_{SENSE} :

EX1 : If current limit setting $I_{LIMITED} = 3A$; $R_{SENSE} = \frac{150mV}{I_{LIMITED}} \Rightarrow \frac{150mV}{3A} = 50m\Omega$,

Initial value $R_{SENSE} = 50m\Omega$ 、R3=1KΩ 、C8=22nF, the motor output waveform is as follows :

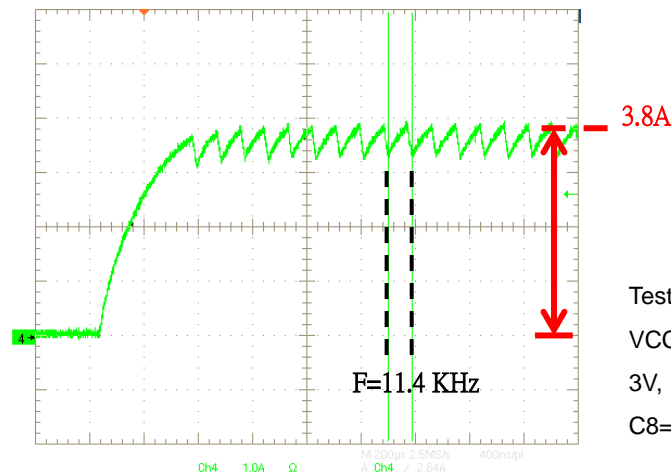

Test Condition :
 VCC=6V, STBYA=STBYB=PWMA=DC
 3V, PWMB=DC 0V, R3=1KΩ、
 C8=22nF、R_{LIMIT}=50mΩ

There are different type motors which have different inductive reactance and resistance, customers have to follow real motor load status to optimize R_{SENSE} limit value; therefore, please follow step 2、step 3 to optimize C8 and R_{SENSE} value again.

Step 2. Optimize C8 to make motor output working frequency in 20~40KHz range :

EX2 : Change C8 from 22nF to 10nF, R3=1KΩ (R_{SENSE}=50mΩ) stays the same, the output current waveform is as follows :

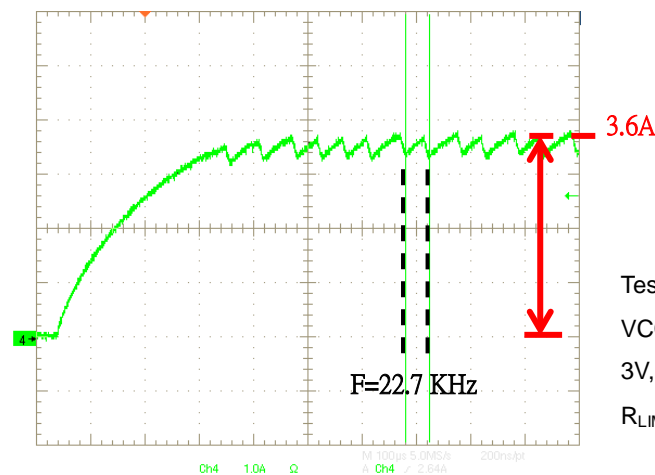

Test Condition :
 VCC=6V, STBYA=STBYB=PWMA=DC
 3V, PWMB=DC 0V, R3=1KΩ、C8=10nF、
 R_{LIMIT}=50mΩ

Result : The output frequency is in 20~40 KHz range after C8 value is changed.

Note 2 : After C8 value is optimized for different type motor load, the current limit clamp level is shifted, customers have to follow step 3 to optimize R_{SENSE} value to obtain correct current limit clamp level.

Step 3. Optimize R_{SENSE} :

Base on step 2 output waveform result, please optimize R_{SENSE} value again to obtain correct current limit clamp level I_{LIMITED}.

EX3 : Fix R3, C8 value, optimize R_{SENSE} from 50mΩ to 60mΩ, the output current waveform is as follows :

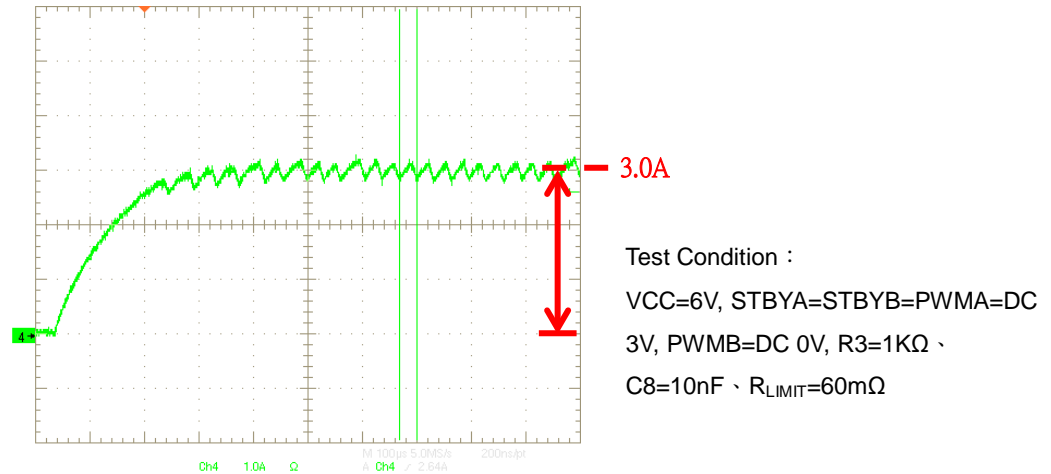

The final setting value are $R_{SENSE}=60m\Omega$ 、 $R3=1K\Omega$ 、 $C8=10nF$, the Current Limit = 3.0A which meets customer application current limit level.

Note1 : When using the same R_{SENSE} and R3 and C8, the current limit clamp level might be different because the different type motor (inductive reactance and resistance might be different) and different VCC value. To get the best current limit clamp level, it needs to test in actual load model when motor type and VCC setting is changed,

Note 2 : If current limit function is not needed, the CS pins should be connected directly to ground.

7) Over-temperature protection :

If the IC junction temperature exceeds $150^{\circ}C$ (Typ.), the internal over-temperature protection function will be triggered, partial FETs in the H-bridge are disabled, that will ensure the safety of customers' products. If the IC junction temperature falls to $110^{\circ}C$ (Typ.), the IC resumes automatically.

● Timing Requirement

Timing parameter	Parameter	Typical value	Unit	Condition
Output rising time	T_r	20	ns	$T_A = 25^\circ\text{C}$, $V_{CC} = PV_{CC} = 10\text{ V}$, $F_{\text{PWM}_X} = 10\text{ kHz}$, $R_{\text{load}} = 20\ \Omega$
Output falling time	T_f	20	ns	
Output rising delay time	T_{rd}	600	ns	
Output falling delay time	T_{fd}	100	ns	

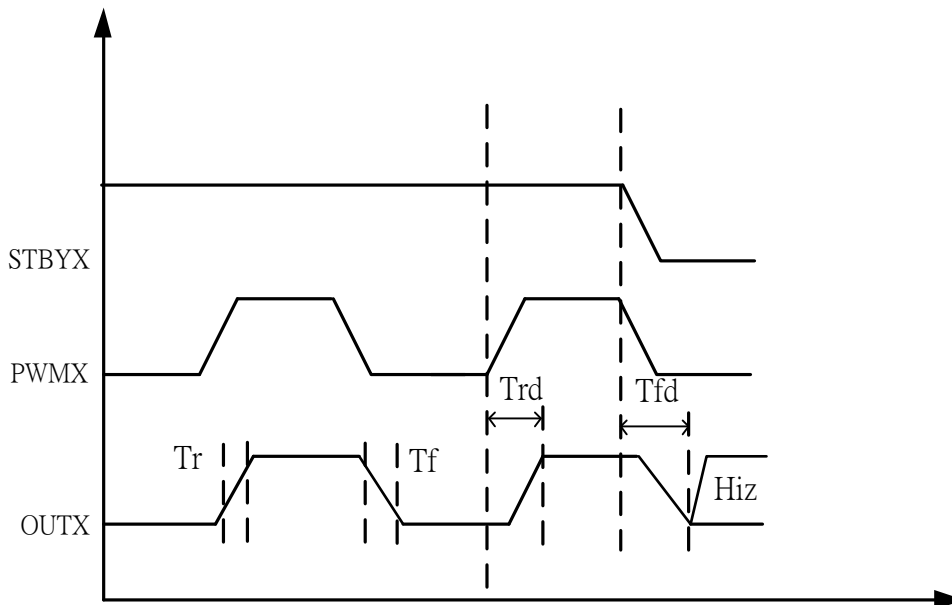

- 1) T_r : Output rising time, output voltage rising from 10% to 90%.
- 2) T_f : Output falling time, output voltage falling from 90% to 10%..
- 3) T_{rd} : Delay time, PWMX low to OUTX high.
- 4) T_{fd} : Delay, time, PWMX high to OUTX Low.

● **Truth Table**

The PWMX and STBYX pins control the state (high or low) of the OUTX outputs. Table1. Shows the logic:

STBYX	PWMX	OUTX
0	X	Hi-Z
1	0	L
1	1	H

Table1. Logic States

Note:

Z : High impedance

● Thermal Information

θ_{ja}	junction-to-ambient thermal resistance	41.5°C/W
Ψ_{jt}	junction-to-top characterization parameter	0.6°C/W

- **θ_{ja}** is obtained in a simulation on a JEDEC-standard 2s2p board as specified in JESD-51.
- The **θ_{ja}** number listed above gives an estimate of how much temperature rise is expected if the device was mounted on a standard JEDEC board.
- When mounted on the actual PCB, the **θ_{ja}** value of JEDEC board is totally different than the **θ_{ja}** value of actual PCB.
- **Ψ_{jt}** is extracted from the simulation data to obtain **θ_{ja}** using a procedure described in JESD-51, which estimates the junction temperature of a device in an actual PCB.
- The thermal characterization parameter, **Ψ_{jt}**, is proportional to the temperature difference between the top of the package and the junction temperature. Hence, it is useful value for an engineer verifying device temperature in an actual PCB environment as described in JEDEC JESD-51-12.
- When Greek letters are not available, **Ψ_{jt}** is written Psi-jt.
- Definition:

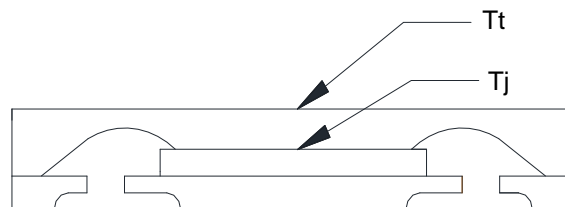

$$\text{DEFINITION } \Psi_{jt} = (T_j - T_t) / P_d$$

Where :

Ψ_{jt} (Psi-jt) = Junction-to-Top(of the package) °C/W

T_j= Die Junction Temp. °C

T_t= Top of package Temp at center. °C

P_d= Power dissipation. Watts

- Practically, most of the device heat goes into the PCB, there is a very low heat flow through top of the package, So the temperature difference between **T_j** and **T_t** shall be small, that is any error caused by PCB variation is small.
- This constant represents that **Ψ_{jt}** is completely PCB independent and could be used to predict the **T_j** in the environment of the actual PCB if **T_t** is measured properly.

● **How to predict Tj in the environment of the actual PCB**

Step 1 : Used the simulated Ψ_{jt} value listed above.

Step 2 : Measure Tt value by using

➤ **Thermocouple Method**

We recommend use of a small ~40 gauge(3.15mil diameter) thermocouple. The bead and thermocouples wires should touch the top of the package and be covered with a minimal amount of thermally conductive epoxy. The wires should be heat-insulated to prevent cooling of the bead due to heat loss into wires. This is important towards preventing “too cool” Tt measurements, which would lead to the calculated Tj also being too cool.

➤ **IR Spot Method**

An IR Spot method should be utilized only when using a tool with a small enough spot area to acquire the true top center “hot spot”.

Many so-called “small spot size” tools still have a measurement area of 0~100+mils at “zero” distance of the tool from the surface. This spot area is too big for many smaller packages and likely would result in cooler readings than the small thermocouple method. Consequently, to match between spot area and package surface size is important while measuring Tt with IR sport method.

Step 3 : calculating power dissipation by

$$P \cong (VCC - |V_{0_Hi} - V_{0_Lo}|) \times I_{out} + VCC \times Icc$$

Step 4 : Estimate Tj value by

$$Tj = \Psi_{jt} \times P + Tt$$

Step 5: Calculated Θ_{ja} value of actual PCB by the known Tj

$$\Theta_{ja(\text{actual})} = (Tj - Ta) / P$$

Maximum Power Dissipation (de-rating curve) under JEDEC PCB & actual PCB

● Power dissipation curve:

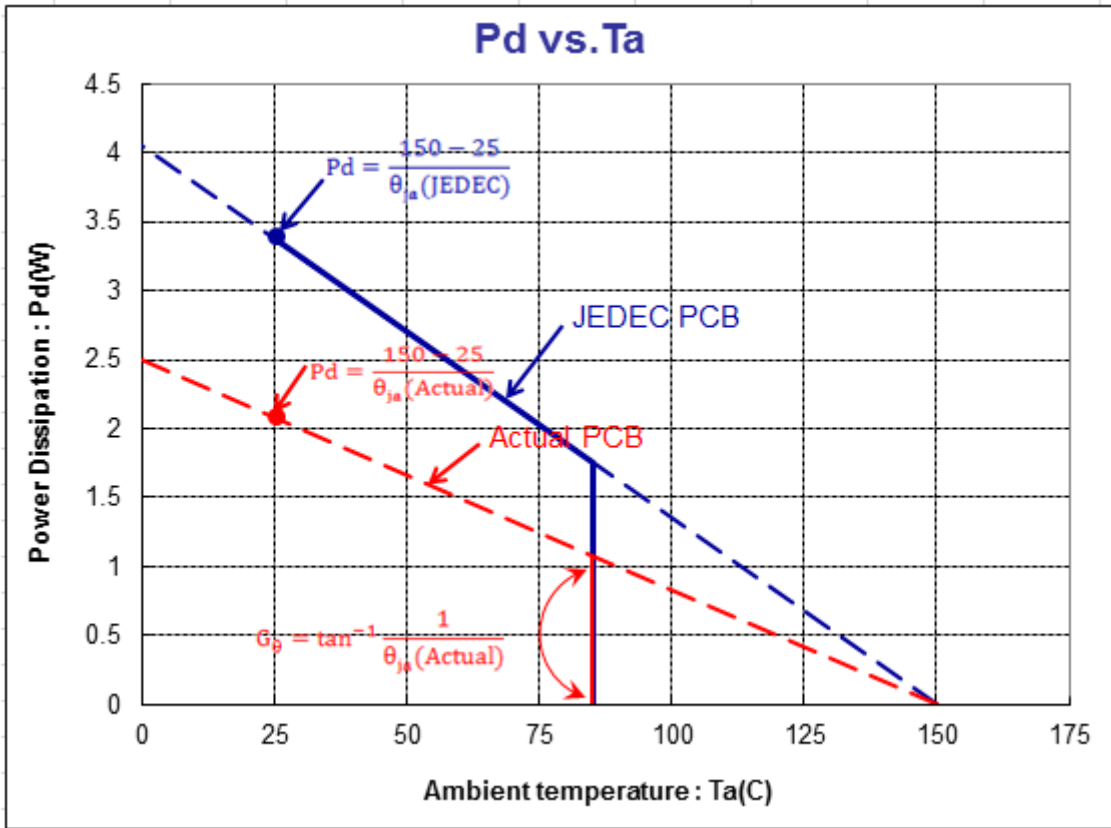

Actual PCB Based on 30x30 mm² FR4 PCB (1 oz.) at double side PCB

● Package outline--- QFN 5x5

Unit :mm

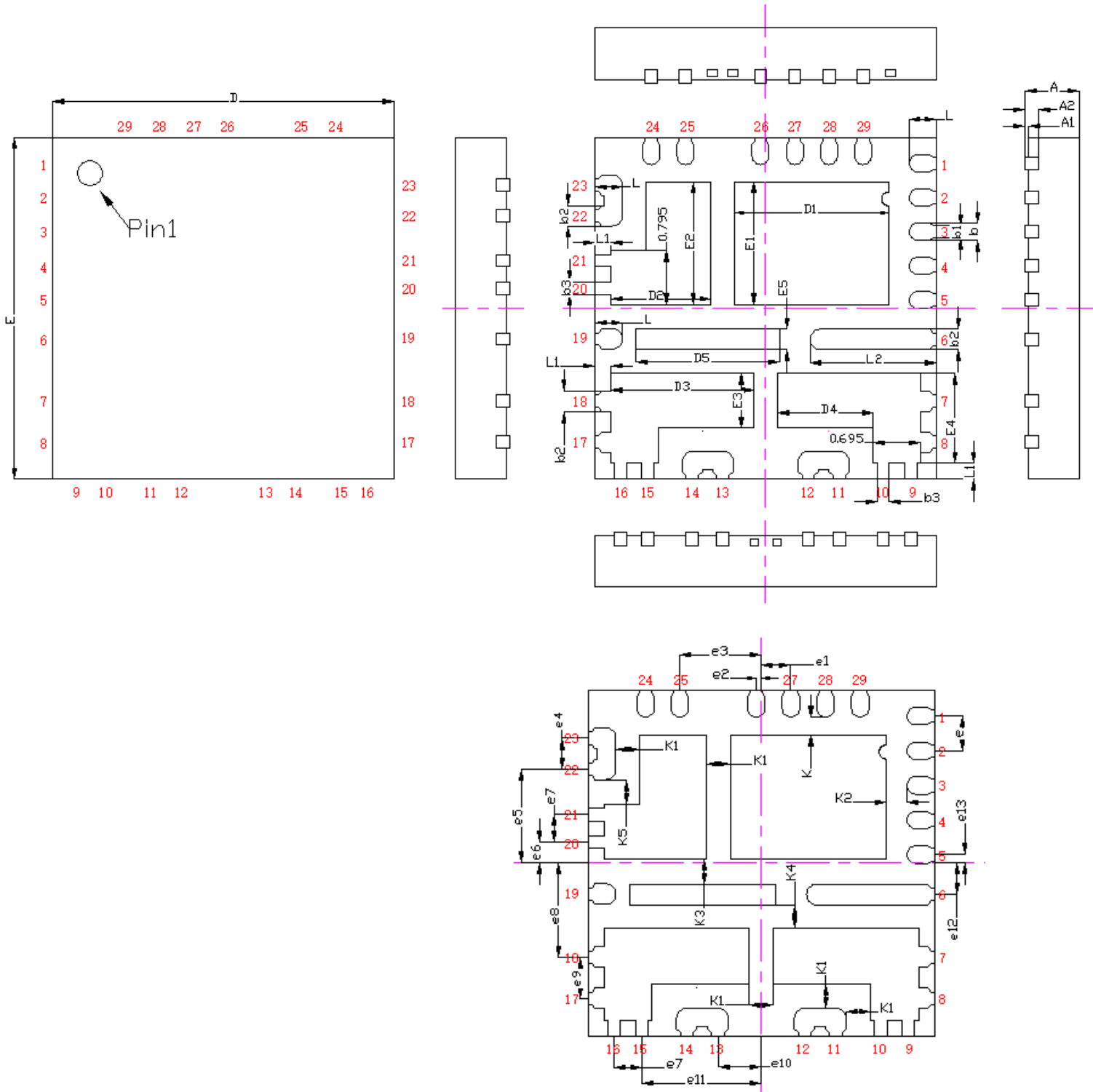



SYMBOL	MILLIMETERS			INCHES		
	Min.	Nom.	Max.	Min.	Nom.	Max.
A	0.70	0.75	0.80	0.028	0.030	0.031
A1	0.00	--	0.05	0.000	--	0.002
A2	0.20 REF			0.008 REF		
D	4.90	5.00	5.10	0.193	0.197	0.200
E	4.90	5.00	5.10	0.193	0.197	0.200
D1	2.20	2.25	2.30	0.087	0.089	0.091
D2	1.42	1.47	1.52	0.056	0.058	0.060
D3	2.045	2.095	2.145	0.081	0.082	0.084
D4	1.35	1.40	1.45	0.053	0.055	0.057
D5	2.05	2.10	2.15	0.081	0.083	0.085
E1/E2	1.752	1.802	1.852	0.069	0.071	0.073
E3	0.748	0.798	0.848	0.029	0.031	0.033
E4	1.268	1.318	1.368	0.050	0.052	0.054
E5	0.25	0.30	0.35	0.010	0.012	0.014
b	0.20	0.25	0.30	0.008	0.010	0.012
b1	0.13	0.18	0.23	0.005	0.007	0.009
b2	0.25	0.30	0.35	0.010	0.012	0.014
b3	0.13	0.18	0.23	0.005	0.007	0.009
L	0.35	0.40	0.45	0.014	0.016	0.018
L1	0.18	0.23	0.28	0.007	0.009	0.011
L2	1.80	1.85	1.90	0.071	0.073	0.075
e	0.50 BSC			0.020 BSC		
e1	0.425 BSC			0.017 BSC		
e2	0.075 BSC			0.003 BSC		
e3	1.175 BSC			0.046 BSC		
e4	0.45 BSC			0.018 BSC		
e5	1.35 BSC			0.053 BSC		
e6	0.3055 BSC			0.012 BSC		
e7	0.40 BSC			0.016 BSC		
e8	1.363 BSC			0.054 BSC		
e9	0.595 BSC			0.023 BSC		
e10	0.625 BSC			0.025 BSC		
e11	1.7225 BSC			0.068 BSC		
e12	0.458 BSC			0.018 BSC		
e13	0.117 BSC			0.005 BSC		
K	0.25 BSC			0.010 BSC		
K1	0.35 BSC			0.014 BSC		
K2	0.30 BSC			0.012 BSC		
K3	0.356 BSC			0.014 BSC		
K4	0.344 BSC			0.014 BSC		
K5	0.357 BSC			0.014 BSC		

● **Marking Identification**

Package Type : QFN 5X5

Device : AM2789

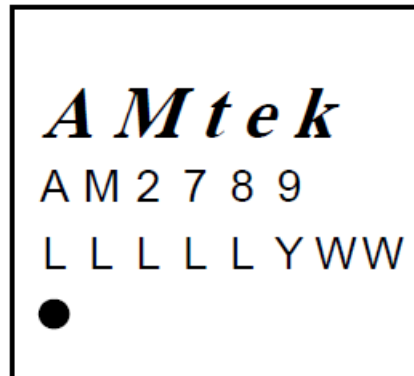

NOTE:

Row1 : Logo

Row2 : Device Name

Row3 : Row3 : Wafer Lot No use five codes 、 Assembly Year use one code 、 Assembly Week use two codes

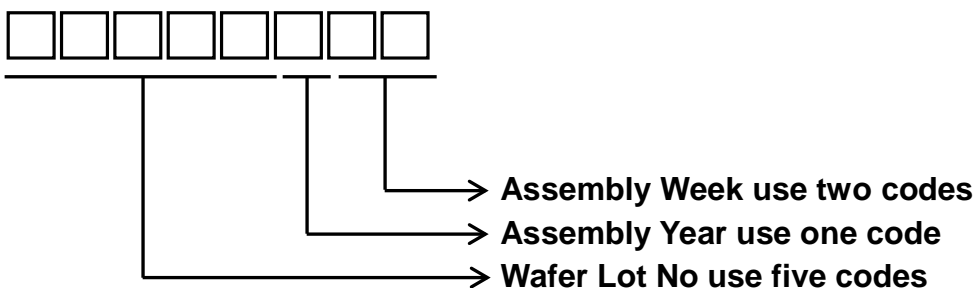

Example : Wafer lot no is FG268 + Year 2019 is J + Week 49 is 49 , we type "FG268J49"

The last code of assembly year, explanation as below: :

(Year : A=0,B=1,C=2,D=3,E=4,F=5,G=6,H=7,I=8,J=9. For example: year 2019=J)

Notice : The information in this document is subject to change without notice. Please contact AMtek for current specifications.

Users should warrant and guarantee that third party Intellectual Property rights are not infringed upon when integrating AMtek products into any application. AMtek will not assume any legal responsibility for any said applications.